

Building the Perfect Distance Cars

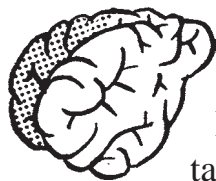

Brain Tip

Key Ideas you should consider when building a good distance vehicle

- **Longer lever arms** The more string that can be pulled off the drive axle translates into more turns that the wheels can make, this causes your vehicle to cover more distance under the pulling force.
- **Large Drive Wheel(s)** Large drive wheels cover more linear distance for each rotation than a smaller diameter wheel. The best wheels tend to be between 1-2 feet in diameter.
- **Small Drive Axle** You can get more turns with a smaller axle for the same length of string than with a larger one. More turns of the axle means more turns of the wheel, which means greater travel distance.
- **Small Power Output** Vehicles that move slower tend to be more energy efficient in comparison to an equally built car of same rolling friction. You can slow a car down by increasing the lever arm length and repositioning the mousetrap further from the drive axle. At low speeds, air resistance is not a large factor in the motion of a moving object, but as the speed of an object increases, the force of air resistance also increases; therefore, at higher speeds moving objects will have to expend more energy to maintain constant velocity. For this reason, it is best to build a slow moving distance car!

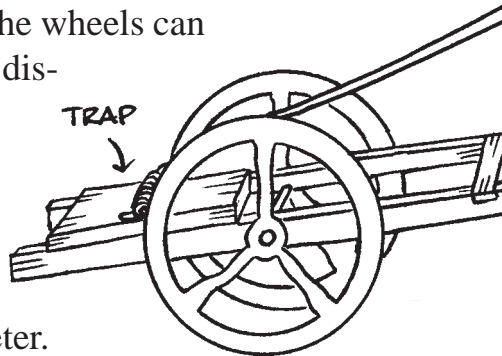

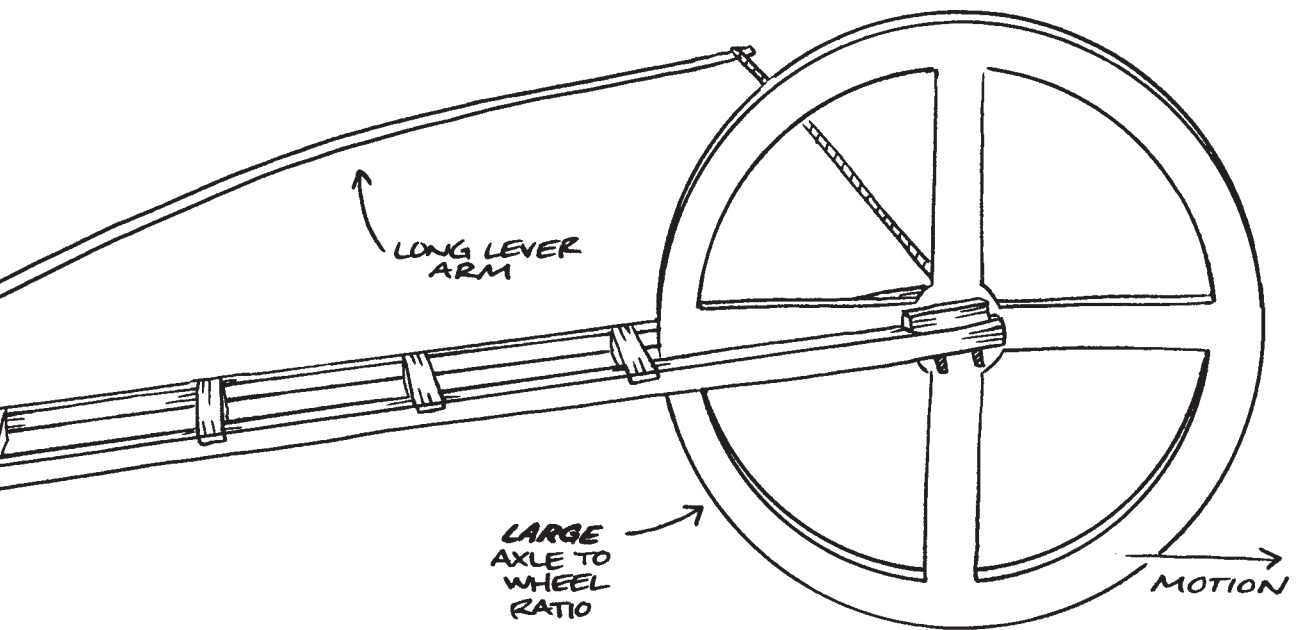

Decrease Mass and Rotational Inertia Build a lightweight frame and use lightweight wheels. Remove mass from wheels to decrease rotational inertia.

- **Sample Different Mousetraps** Not all mousetrap springs have the same spring tension. The greater the tension in a mousetrap, the more energy you will be able to store when the spring is wound-up.
- **Remove ALL Friction** This one is impossible but the more you can reduce friction, the less energy that will be lost to heat and sound which translates into greater travel distance. Your vehicle should have the lowest possible energy consumption; this means that your vehicle should be a slow mover and use ball bearings.

Using these principles, mouse-trap cars have traveled 100⁺ meters!

Distance Car

Ideas for Increasing Distance

1

Decrease rolling friction by re-working the friction points. Polish bushings or use ball bearings. If you are using bearings, soak them in WD-40; this will remove any oil or grease. Although grease and oil are lubricants and often used to reduce friction, adding them to mouse-trap car bearings slows the car down because of the large viscosity of the lubricants.

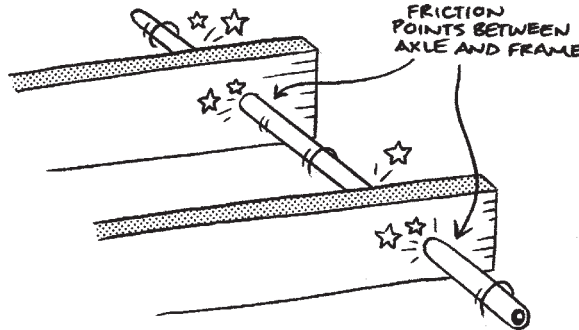

54

2

Decrease the force required to pull the vehicle by decreasing the rotational inertia. Decrease the rotational inertia by removing mass from the inside of the wheels. Decrease the overall mass of the car by removing mass from the frame and use a light-weight lever arm. Move the trap away from the pulling axle and extend the lever arm. Re-adjust the string and the string attachment point. Don't add mass around the outside of wheels such as rubber bands or balloons.

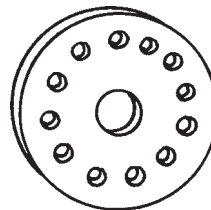
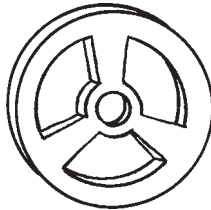

3

Use a larger drive wheel. Try making a wheel out of mat board. Mat board is stiff and light weight.

Distance Car

4

Use a smaller drive axle. The larger the ratio of drive wheel(s)-to-axle(s) diameter, the farther you car will go for each turn of the wheel and the greater the pulling distance will be.

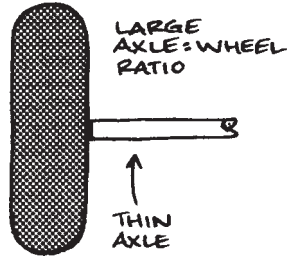

5

Find a stronger mouse trap. Test different mouse traps in order to find the strongest one.

6

If your car is stopping and the spring is not at its resting point, find a stronger mouse trap or try to make a tapered axle so you can change the torque required to turn the wheels as the pulling force to the drive axle changes, or build up the drive axle with tape.

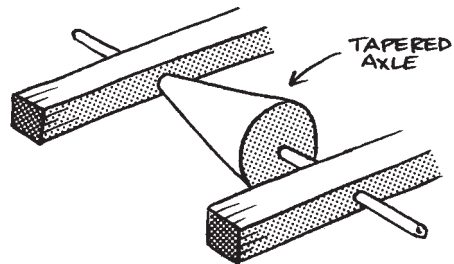
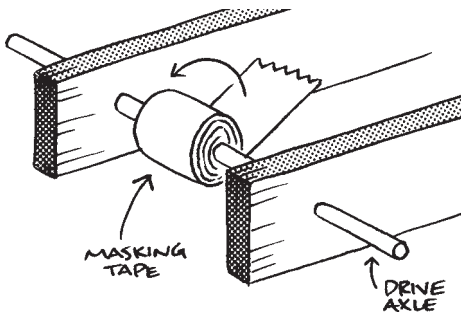

7

Check string alignment and make sure that the string is attached directly over the drive axle with the lever arm held in the fully wound position.

Building the Perfect Speed Cars



Brain Tip

Key Ideas you should consider when building a good speed vehicle. Using these principles, I have seen mouse-trap cars travel 5 meters in under 1 second!

- **Shorter lever arms** shorter lever arms have more pulling force, more pulling force means greater acceleration, greater acceleration mean less time before the vehicle reaches top speed. If the lever arm is too short your vehicle will slip off the start and will waste energy. Therefore, adjust the lever length in order to find the best performance
- **Smaller Drive Wheel(s)** Wheels should be around 2-5 inches in diameter but no larger than a compact disc. If the wheel-to-axle ratio too small your vehicle will slip off the start and will waste energy. Therefore, adjust the ratio in order to find the best performance
- **Increase the Traction** Use rubber bands on the drive wheels and/or Traction Action[®] on the wheels in order to increase the traction. More traction means greater acceleration.
- **Larger Diameter Drive Axle** You can get more torque with a thick axle. More torque means greater acceleration! You can build the axle up with tape to increase the axle diameter.
- **Large Power Output** The vehicle should be designed to have a large energy consumption in a short period of time (i.e., a large power output). A vehicle that can get-up to its top speed as fast as possible will have a shorter time over a timed distance. With a car designed for speed , the objective is how quickly can the vehicle convert its potential energy into kinetic energy.

- **Decrease Mass and Rotational Inertia** MORE IMPORTANT WITH A SPEED CAR THAN A DISTANCE VEHICLE. Build a lightweight frame and use lightweight wheels. A wheel with a large rotational inertia can really limit a cars performance, remove as much mass as possible from wheels to decrease rotational inertia.
- **Sample Different Mousetraps** Not all mousetrap springs have the same spring tension. The greater the tension in a mousetrap, the more energy you will be able to store when the spring is wound-up.
- **Remove ALL Friction** This one is impossible but the more you can reduce friction, the less energy that will be lost to heat and sound, which translates into greater speed. Your vehicle should have the lowest possible energy consumption do to friction; this means that your vehicle should use ball bearings.

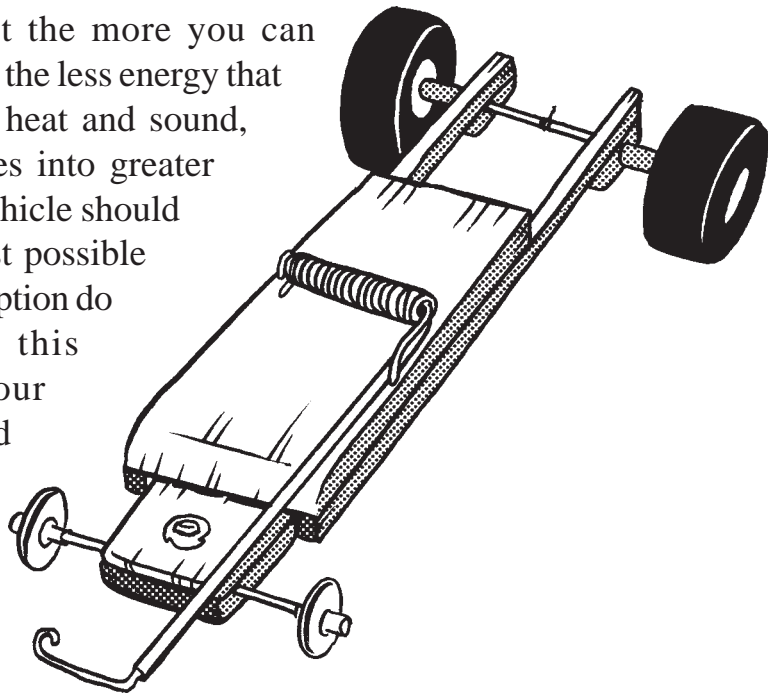

Speed Car

Ideas for Increasing Speed

- 1** Move the mouse trap closer to the drive axle as long as the wheels are not spinning and decrease lever arm accordingly.

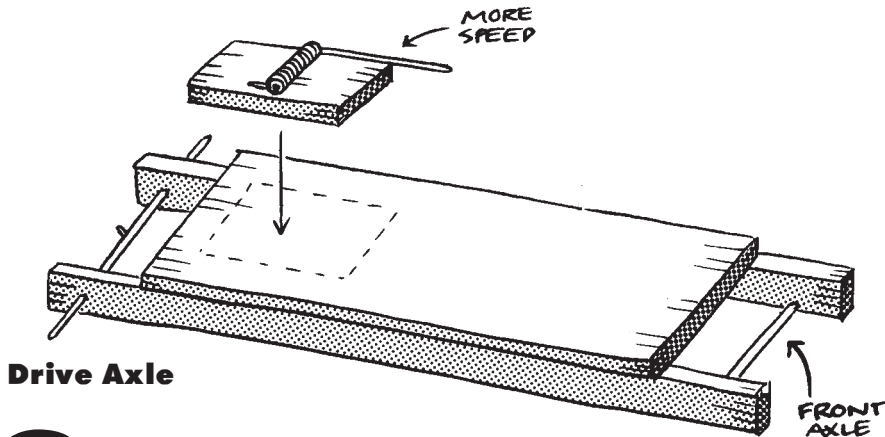

58

- 2** Increase traction on drive wheels by using rubber bands or the middle section of a rubber balloon around the drive wheels. Try adding mass directly above the drive axle.

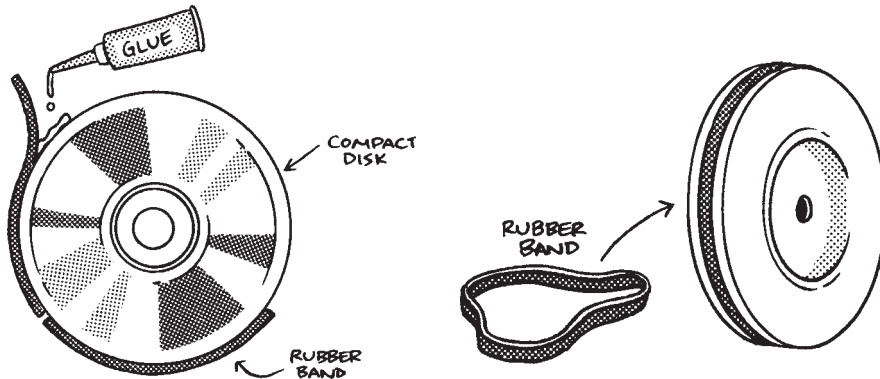

- 3** Move the trap away from drive wheel(s) **only if the wheels are slipping**. This will decrease the pulling force which is the reason for the slipping wheels.

Speed Car

4 Decrease rolling friction by re-working the friction points. Polish bushings or use ball bearings. If you are using bearings, soak them in WD-40; this will remove any oil or grease. Although grease and oil are lubricants and often used to reduce friction, adding them to mouse-trap car bearings slows the car down because of the large viscosity of the lubricants.

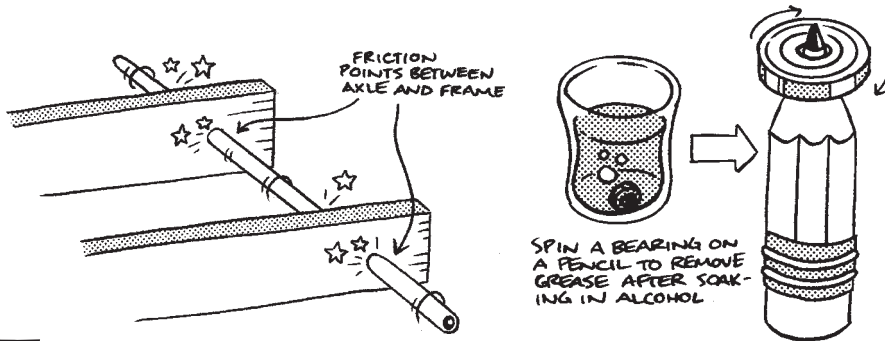

5 Decrease rotational inertia of wheels by removing mass from the inside of the wheels. Also, try smaller diameter wheels.

6 Adjust the wheel-to-axle ratio by adding or removing tape on the drive axle.

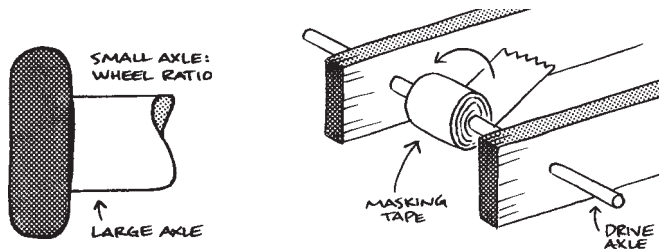

7 Check string alignment and make sure that the string is attached directly over the drive axle with the lever arm held in the fully wound position.

Common problems with both Distance and Speed cars

PROBLEM:

Axle slides back and forth causing wheels to rub against the frame of the car, slowing or stopping the car.

1. Add thrust washer between wheels and the frame for a smoother rubbing surface with less friction.

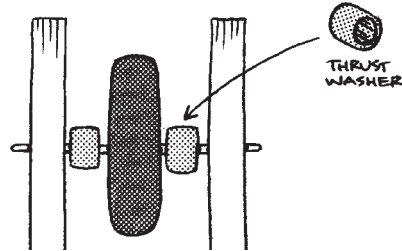

2. Make spacers out of brass tubing to hold the wheels in place and limit the side-to-side play of the wheels or axles.
3. If you are using bearings, the axle may be moving side to side. Carefully glue the axles to the bearings without getting glue in the bearings.

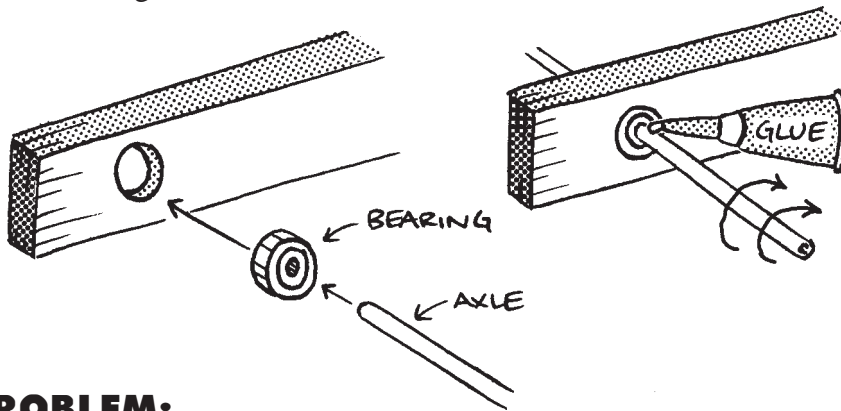

PROBLEM:

Can't find an axle to fit the wheels or bearings.

1. Re-size the axle or change the wheel's hole size with a spacer.



PROBLEM:

Mouse trap falls quickly but car moves slowly.

1. Drive wheels are not glued to the axle and the axle is spinning inside the wheels. Glue wheels to axle.

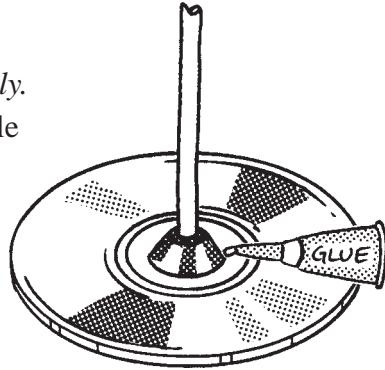

2. There is no hook on the axle for attaching the string and/or the string is slipping off the axle without pulling. The hook may not be glued to the axle and is slipping under the tension of the string.

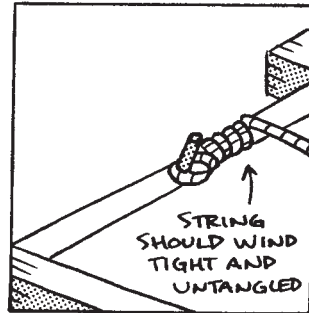
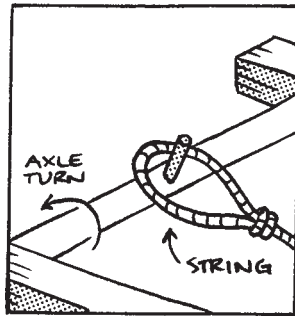

PROBLEM:

Mouse trap car does not start or moves slowly.

1. Too much friction in the rolling points. Re-do the rolling points or try ball bearings.

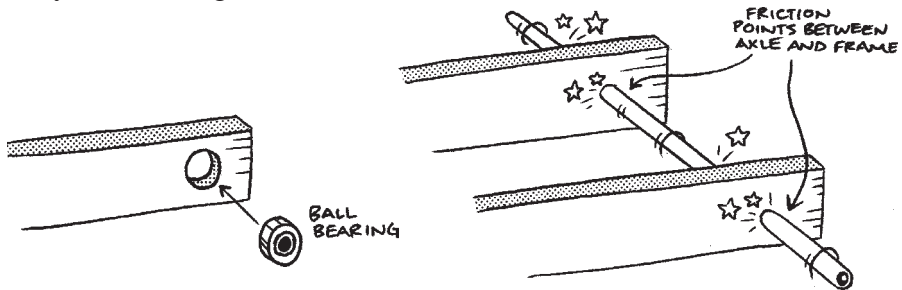

Technical Help

PROBLEM:

Mouse trap car does not start or moves slowly. (Continued)

2. Not enough tension in the pulling string. Move the trap closer to the drive axle and adjust the string attachment point on the lever arm accordingly *or* try to build up the drive axle with tape. Lastly, test different mouse traps and use the strongest one.

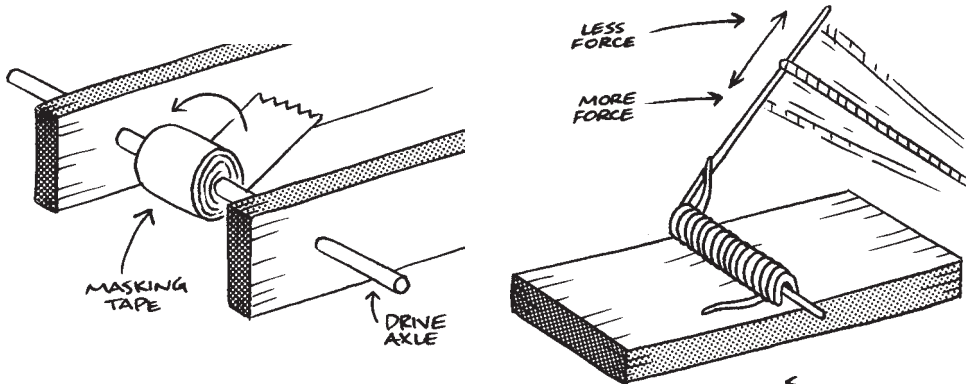
**PROBLEM:**

Mouse trap car does not travel straight.

1. Wheels are not pointing in the same direction. The solution is to bring the wheels into alignment. If the vehicle is a three-wheeled vehicle you need to focus your efforts on the single wheel. Try to align it with the other two. This is not easy!
2. This only applies to long distance cars that use one large wheel as the drive wheel. If the car travels straight when you push it without the tension of the lever arm, but turns once under the pulling tension of the trap, there is too much frame flex or the trap is pulling too hard on one side of the axle. Strengthen the frame or prevent the pulling side of the axle from giving too much at its holding points.

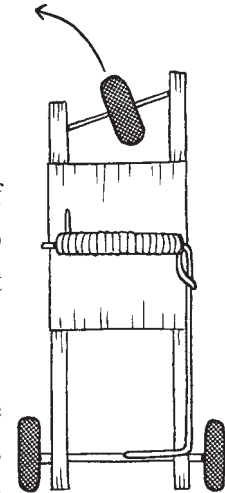
**Technical Help**

PROBLEM:

Mouse-trap car suddenly stops or slows quickly.

1. The string is not releasing from the drive axle because it is either glued to the axle or it is too long *or* the hook is too long and catching the string causing it to rewind.

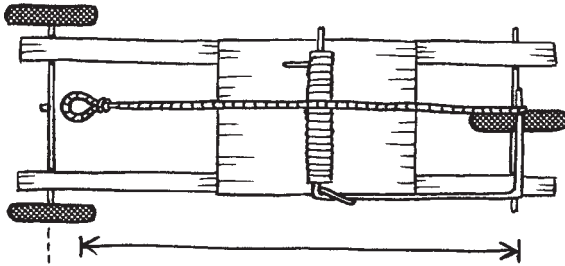

Cut string a little bit shorter than what is needed in order to insure a proper release.

2. There is too much friction at the rolling points. Re-work the bearings to reduce friction or try ball bearings. Try a small diameter axle.

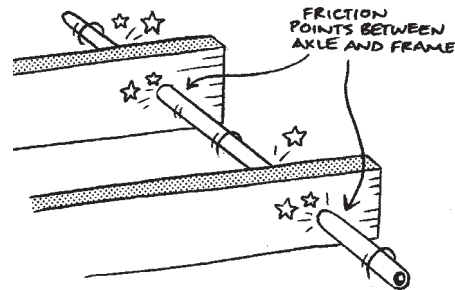
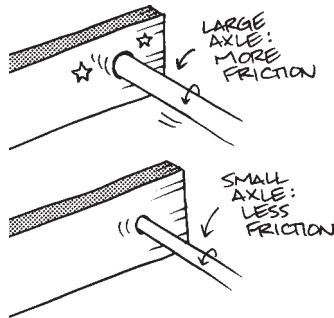

3. Wheels are rubbing on the frame. Prevent wheels from rubbing with spacers or thrust washers.

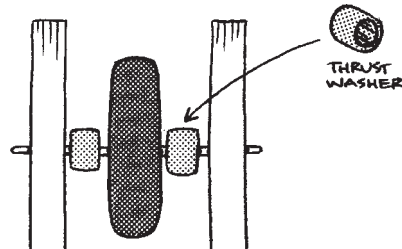

Technical Help